

# **TRIKKE**<sup>™</sup> PROFESSIONAL MOBILITY



**POSI.TRON**

## **Owner's Manual**

**TRIKKE POSITRON**

**TRIKKE Defender and TRIKKE Positron are professional grade Light Electric Vehicles (LEV) for personal mobility.**

**Developed to offer quick and efficient transport of an individual in a wide range of terrain: street, sidewalk, walk paths, on and off-road, indoor and outdoors.**





FIRST ASSEMBLY VIDEO

## FIRST ASSEMBLY (watch assembly video)

- 1) Remove the unit from the packing box
- 2) Unfold the frame, lock the folding levers.
- 3) Attach handlebar (cables route in front of the handlebar post), align with front wheel, tight handlebar clamp bolts really well.
- 4) Attach the siren to the top of front structure (60V model, 72V does not need it).
- 5) Secure the cables loom to the side of the front structure with the small clamps.
- 6) Install battery – a) battery must be switched OFF b) make sure the key-lock pin is retracted (counterclockwise). c) identify front and back side of the battery d) place the battery on the tray tilted to the back. e) push the battery forward against the lock all the way and turn the key clockwise to lock. Remove the key from the lock and place in a safe place.
- 7) Check/calibrate tires pressure. Use a floor pump or electric pump with a reliable gauge. Front 50psi, Rear 65psi.

## UNFOLDING

- 1) Retract the lock knob on each folding mechanism (LH and RH) about 3/8" (1cm)
- 2) Unfold the frame
- 3) Press down the tensioners (while leaning the vehicle to the opposite side) until it snaps into locked position
- 4) Screw the knobs in until it locks. These will be on top of the tensioners as a safety pin.

## FOLDING

- 1) Retract the lock knob on each folding mechanism (LH and RH) until the tip clears the levers.
- 2) Pull the center knob up to unlock the tensioners (while leaning the vehicle to the opposite side)
- 3) Fold the frame
- 4) Screw the knobs into the hole through the lever in order to lock the frame folded. This is imperative for handling and transport.

## Unfolding the Frame

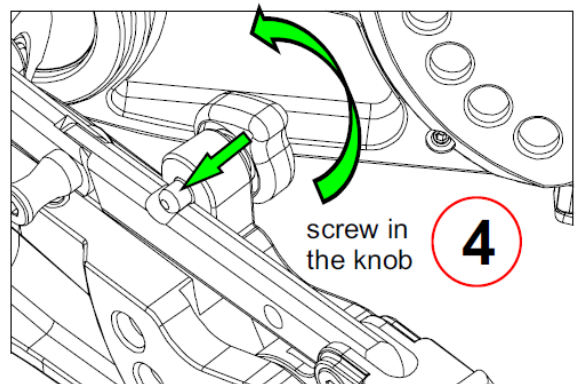
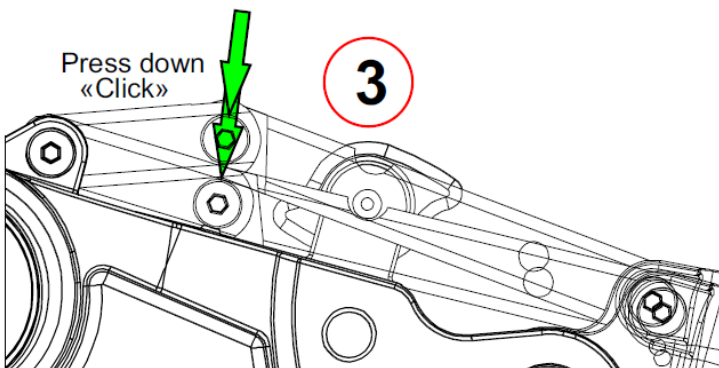
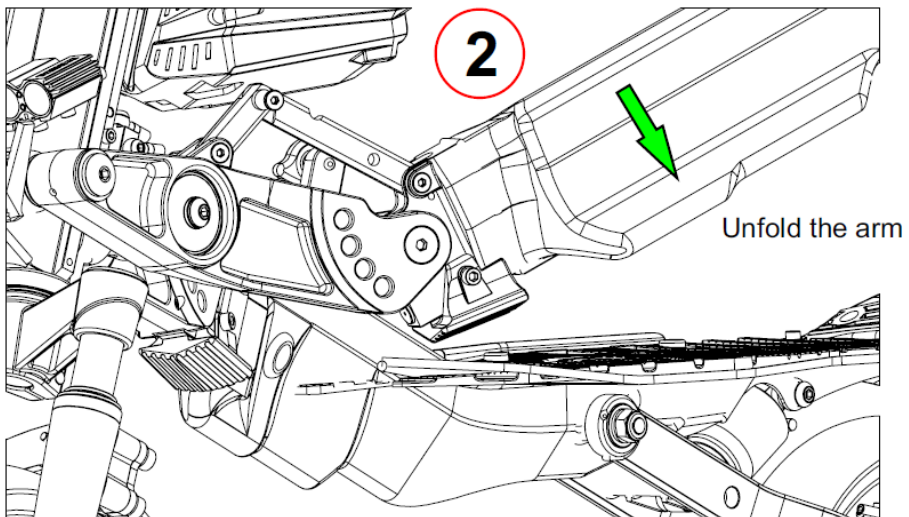
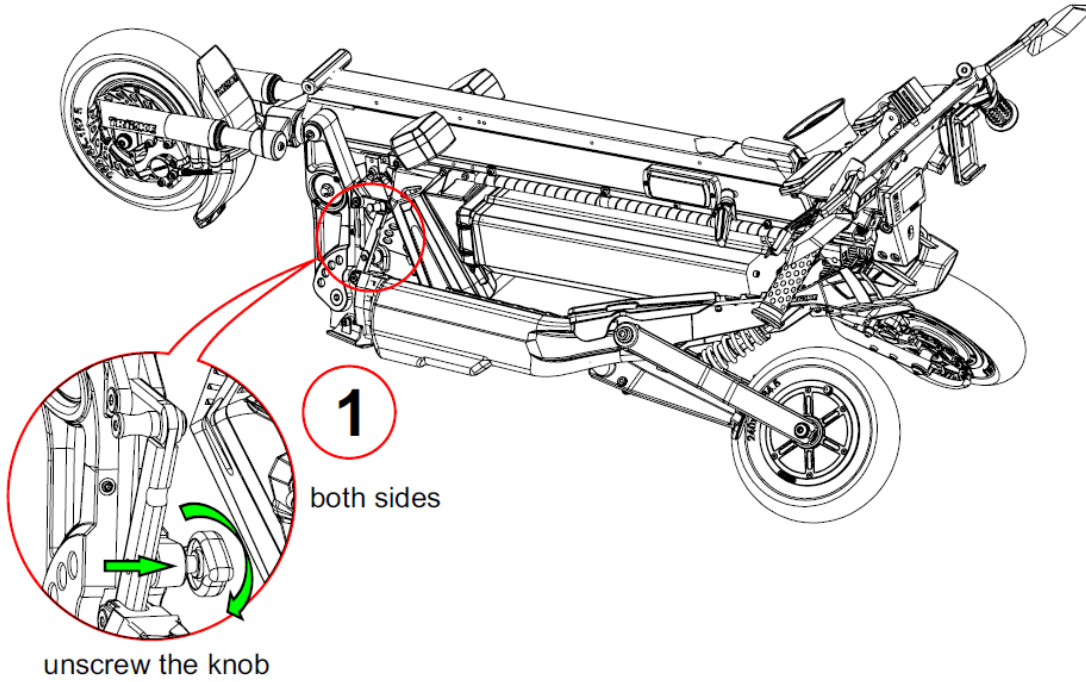

## Handlebar Mounting and Alignment

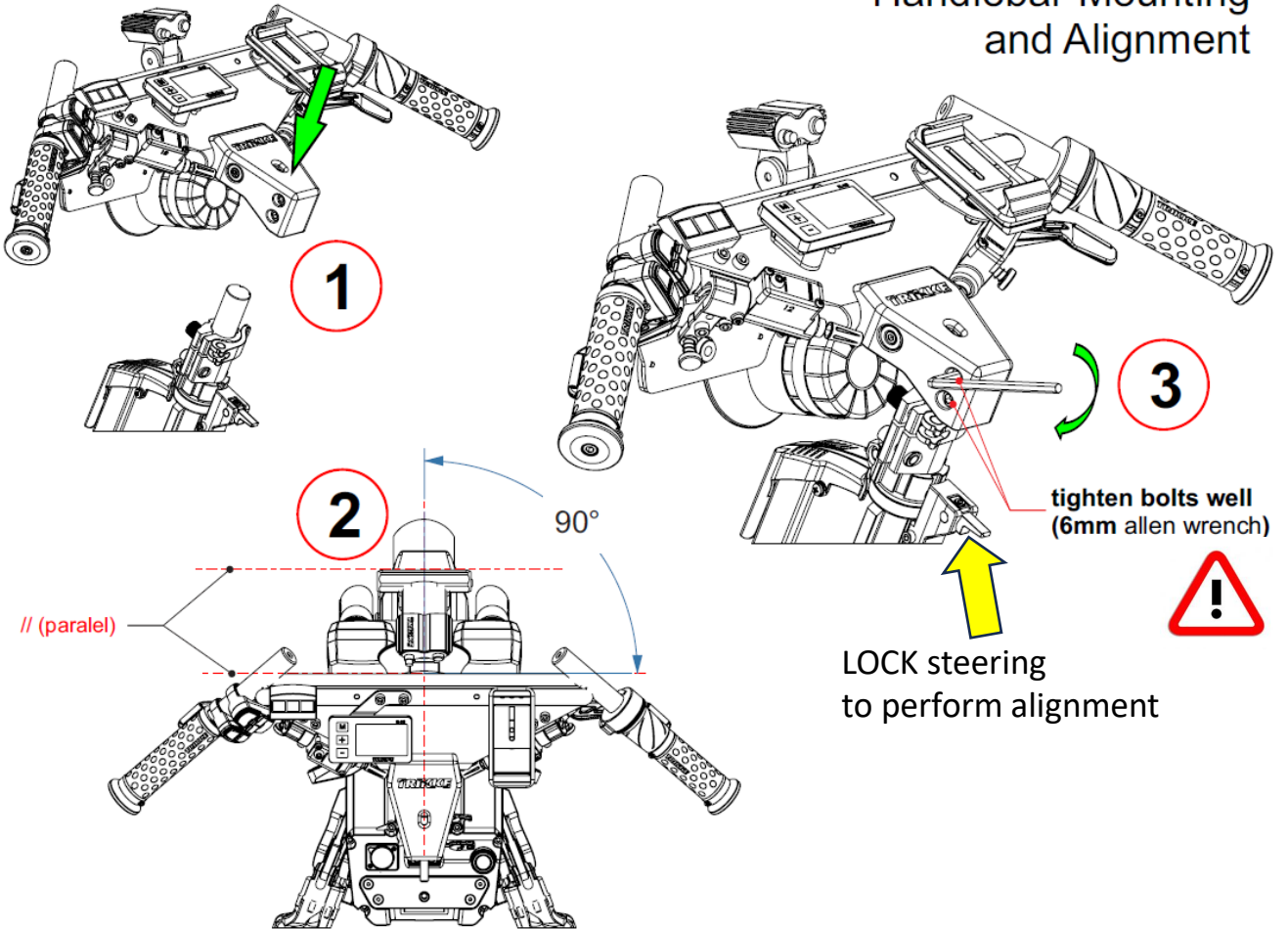

## Securing Cable loom to the frame

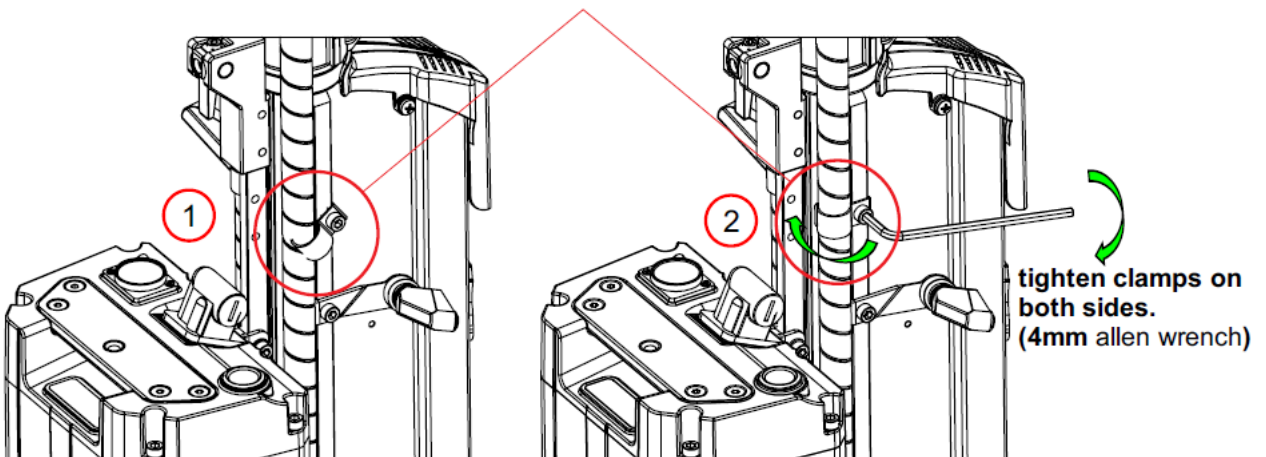

## Installing the Battery



Make sure the battery is switched **OFF** for installation

### Installing the battery

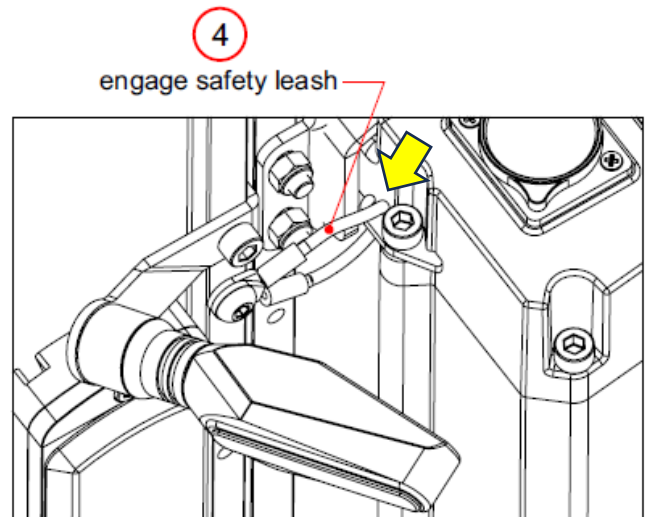
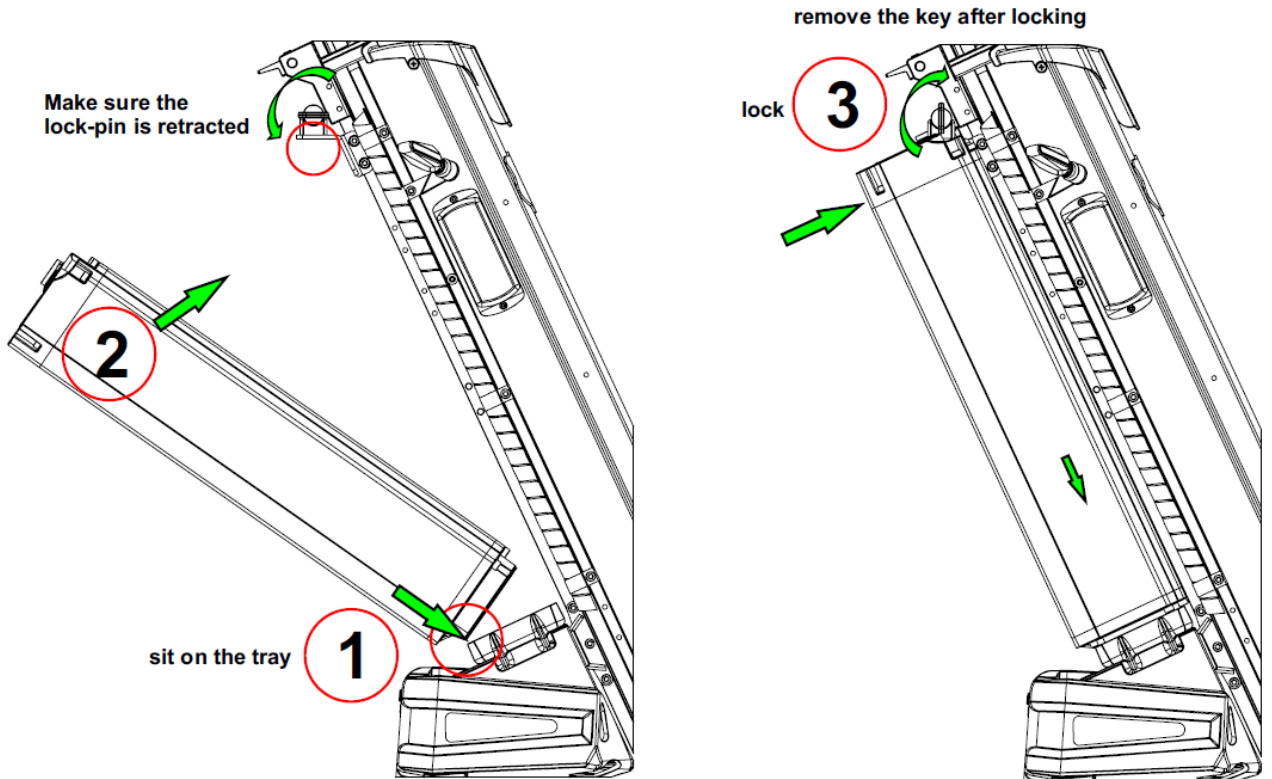

Left side of the vehicle

## Battery

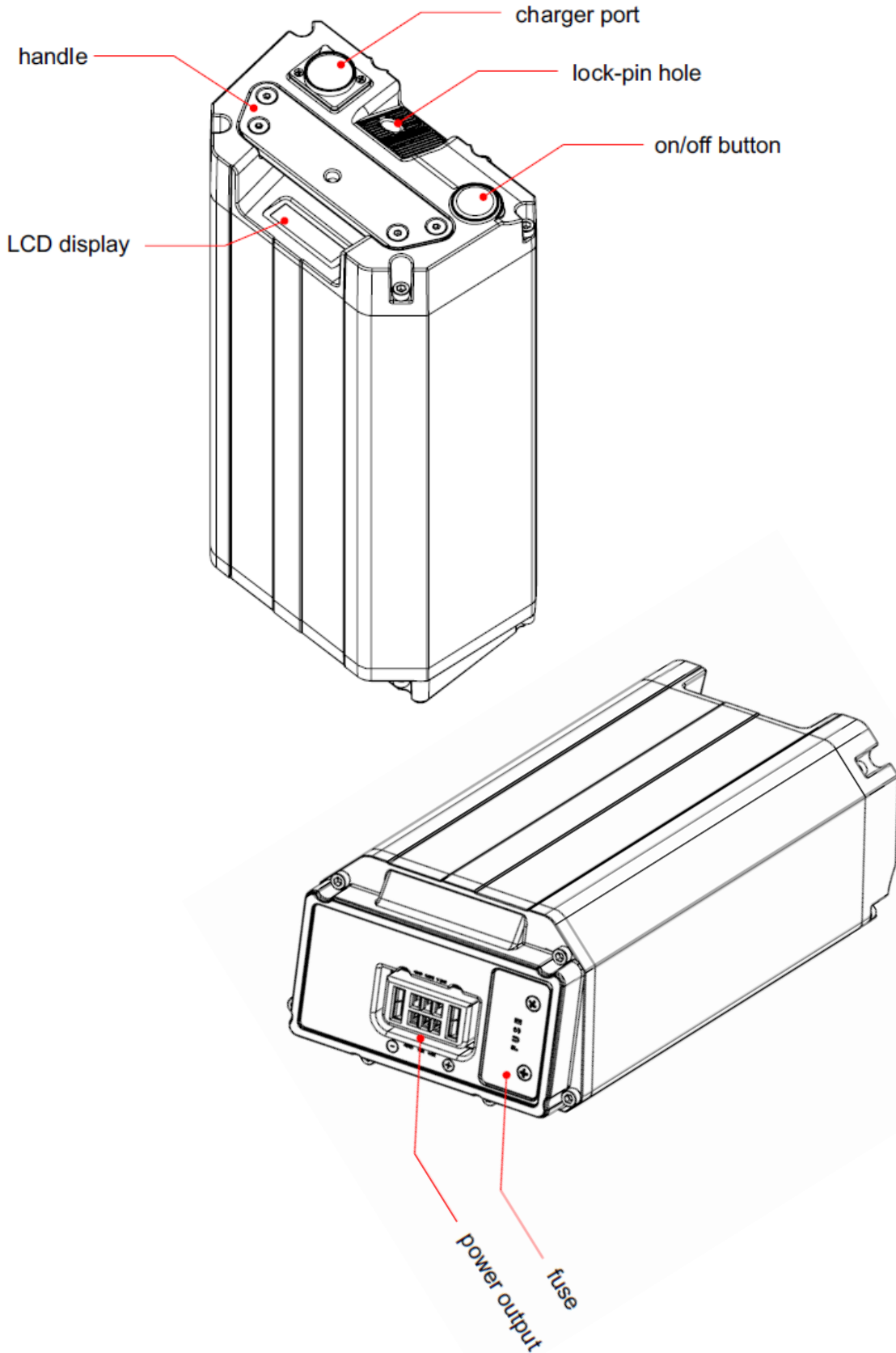



## OPERATION (watch operation tutorial video)

Turn On the battery power: press in the on-off switch.  
The battery LCD will light up showing the % of remaining charge.

Push [M] button on Display to turn ON the drive system.

OPERATION GUIDE VIDEO

By default, the display is selected to PAS 2 (power level 2 of 5). You can increase or decrease the power by using the [+] and [-] buttons

Gently twist the throttle towards you to make the vehicle move forward. The more angle you turn the throttle, the speed will increase.

Use the brake levers situated on both sides of the handlebar to apply brake and reduce speed or stop. Apply brakes evenly and gently. Avoid squeezing the brakes too hard as it cause the wheels to lock and skid. Right hand brake for rear wheels. Left hand brake for front wheel. Do not use front brake heavily while turning, the front wheel may skid or lock, causing loss of control.

## Handlebar mounted controls

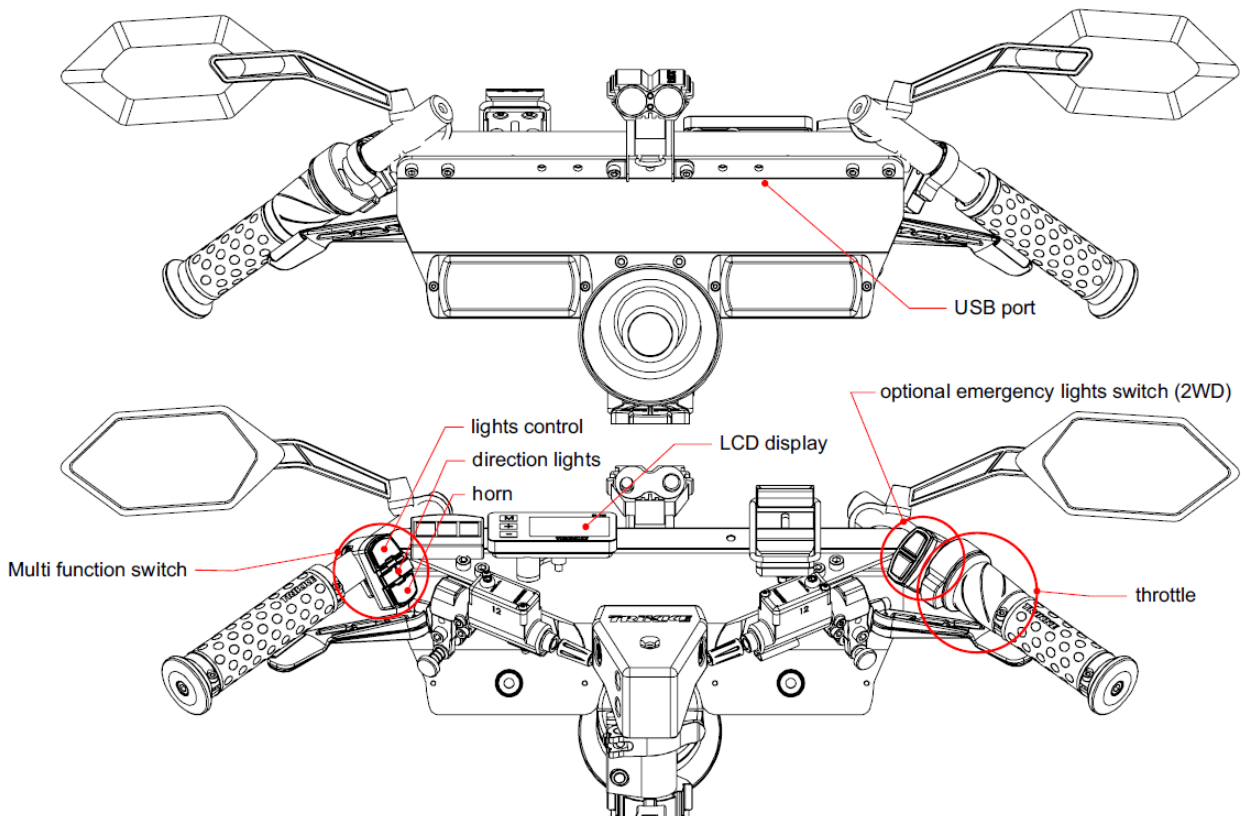

LCD Display - operation

**Turning Display ON-OFF and sleep**  
 \* After switching the battery power ON you will have to press M button to turn the display ON and start the system.  
 \* To turn the system OFF press and hold M button. You may also switch the battery power OFF.  
 \* After a preset time of non-operation, the display will power down (sleep).  
 \* Press M to wake the system up. (models with RFID key swipe the card)



Display X3

**Cruise control**  
 Hold throttle to desired power output. Push and hold [-] until the circle icon comes up. Release the throttle. The system will keep that acceleration level. Twist the throttle to cancel (Defender: brake will cancel)

**Info area - press [M] to cycle through parameters.**

- TRIP (start default) – start new trip at every reset.
- TIMER – start new timer at every reset.
- WATT – instant power
- VOLT – battery voltage
- AVG – average speed of the trip
- MAX – maximum speed of the trip.
- ODO – total mileage (cumulative)

TRIKKE drive system - Display Settings

To enter SETTINGS press [+] and [-] buttons together for 2s. It will prompt for passcode "Cd" (enter 3333)  
 Use [M] button to scroll through parameters P01-P16. Use [+] and [-] buttons to change value.  
 Press and hold [+] and [-] buttons to exit SETTINGS and go back to main screen (or wait for 30s and it will go back to main screen by itself) .  
 By-pass the rfid key ("Card" by holding [-] for 15s. Enter 4 digit code. Use [+] to switch position, use [-] to change numbers.

PARAMETER	description	range	Factory value	NOTE
P01	Speed limiter	0-100% of the top speed	100	100 = 28mph Defender 100 = 37mph Positron 60V 100 = 43mph Positron 72V
P02	Motor magnets count	do not change	30	
P03	Tire circumference	753mm (rear wheel)	753	
P04	unit	Miles ; Km	Miles	
P05	System voltage	48V ; 60V ; 72V	48 / 60 / 72	
P06	System timeout	1-30 minutes	10	
P07	Number of motors	1 (FWD); 2 (2WD); 3 (3WD)	3	
P08	Speed sensor	do not change	1	
P09	Odometer reset	1 ; 0 will reset to zero	1	if you change this parameter to "0" there is no way back.
P10	Starting power assist	1,2,3,4,5 choose default power at start up	2	
P11	Blue Tooth key	not used	0	
P12	Immobilizer (motor jamming)	0 – off ; 1 - on 30 sec delay	1	engages 30s after turning display off. Must keep battery switched ON to work.
P13	Regenerative braking	not used	0	
P14	RFID card pairing	pair up to 3 cards. Show card near the [+] button to pair. Hold [-] button for 10s to delete all cards.	1, 2, 3 ... 0	
P15	Pass Code "Cd" 4 digits	used to access settings and to by-pass rfid key	factory default 3333 can be changed to any passcode	to by-pass RFID key > hold [-] for 20 sec and enter code
P16	Power level limiter	1, 2, 3, 4, 5	5	if select 3, rider can only use 1,2,3 (4 and 5 not available)



## Display X6 (72V XL model)

The new X6 Display has a color screen and features a new button pad which is remote from the main screen, placed on the right handle: [+] [M] [-]

With battery switched ON, press [M] to turn display (the drive system) ON.

To access settings press [+] and [-] together then enter PW 3333 (use + to change position and – to set the number) then hold [+] and you are in.

Press [M] to move through parameters P01 ~P16

See below table of parameters and settings.

If you choose to use NFC access, go to P14, it prompts for a PW 0000 ... enter code 3031 and hold [+] ... P14 will show "0" meaning no phone or NFC card paired yet.

(you may pair up to 3 NFC devices)

Allow (turn on) NFC on your phone. Bring the phone close to the display screen. P14 will turn to "1" then "2" and "3" as you add new phones. To delete the paired phones tap [-] and it will go back to "0".

Access without phone or NFC fob (back door) ... (missing fob or phone)

Press [+] and [-] together until it prompts 0000 then enter PW 3031 ... \*\*\*note that in this situation [+] and [-] change the number up and down and [M] changes position.

Hold [+] after you enter the PW 3031... and you are in.

While you are in, you may want to delete all paired phones. Access settings press [+] and [-] together then enter PW 3333 (use + to change position and – to set the number) then hold [+]. Press [M] multiple times until P14. To delete the paired phones tap [-] and it will go back to "0". Press [+] and [-] together to exit settings.

## Display X6 (72V XL model)

### Parameters settings:

- P01 speed limit as a percentage of the top speed 44mph
- P02 30 (nr of magnets in the motor)
- P03 835 (tire circumference in mm)
- P04 miles or km
- P05 72V
- P06 10 minutes sleep timer
- P07 3 motors
- P08 1
- P09 1 (0 resets the odometer)
- P10 2 (default power at start)
- P11 0
- P12 1 or 0 (turn on or off the wheel immobilizer – only works with battery switched on)
- P13 keep it 0 (e-brake intensity 0-1-2-3)
- P14 0000 enter code 3031 to pair NFC device (smart phone or NFC fob)
- P15 set access password – factory set 3333
- P16 max power level 1,2,3,4,5
- P17 not used

### Error codes:

- Err 0 battery voltage below threshold
- Err 1 motor controller fault
- Err 2 throttle fault (or disconnected)
- Err 3 motor fault (or disconnected)

# PARKING

## a) Lock parking brakes (both sides)

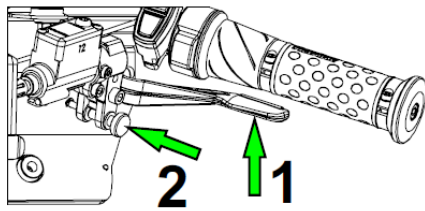
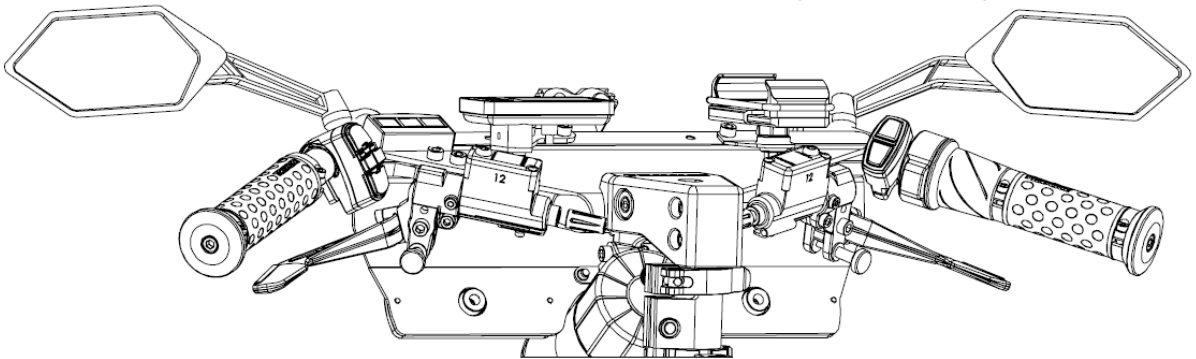

**Lock:**

- 1) squeeze lever
- 2) Push-in the plunger and release lever

**Unlock:**

- Squeeze lever

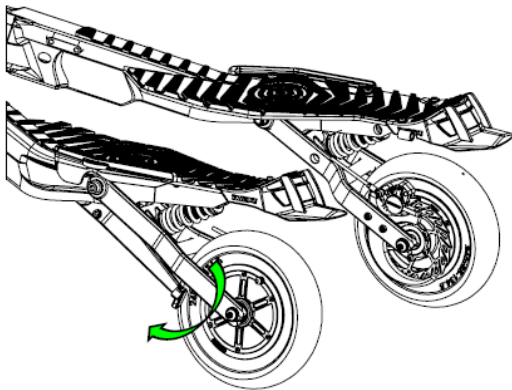

## b) Set the kick-stand

Turn handlebar to the left and lean the vehicle over the kick-stand.

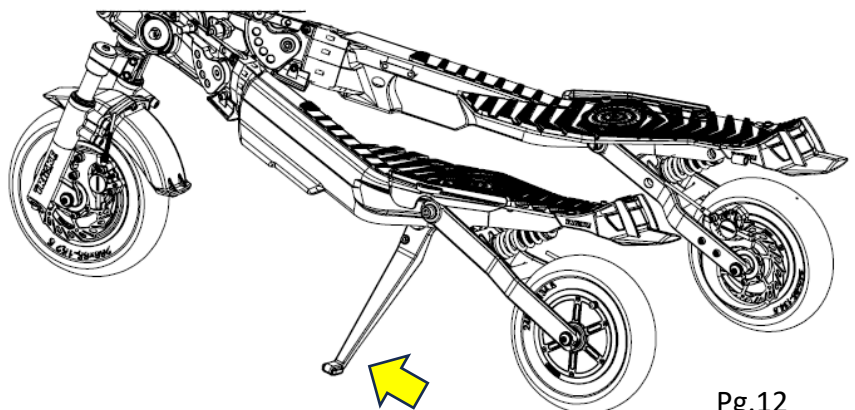

## Steering lock

Useful for transport and maintenance, as well as theft deterrent.

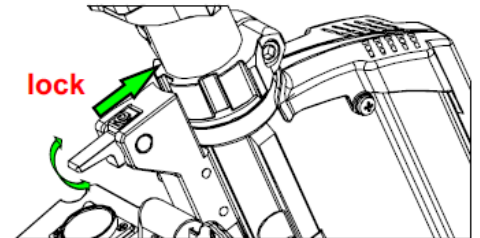
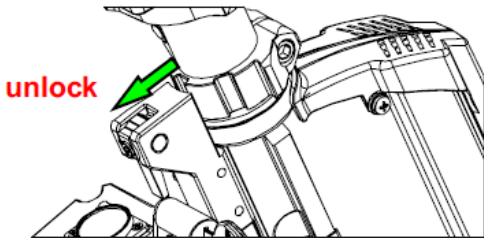

## Handlebar Height Adjustment

Useful for transport and maintenance, as w

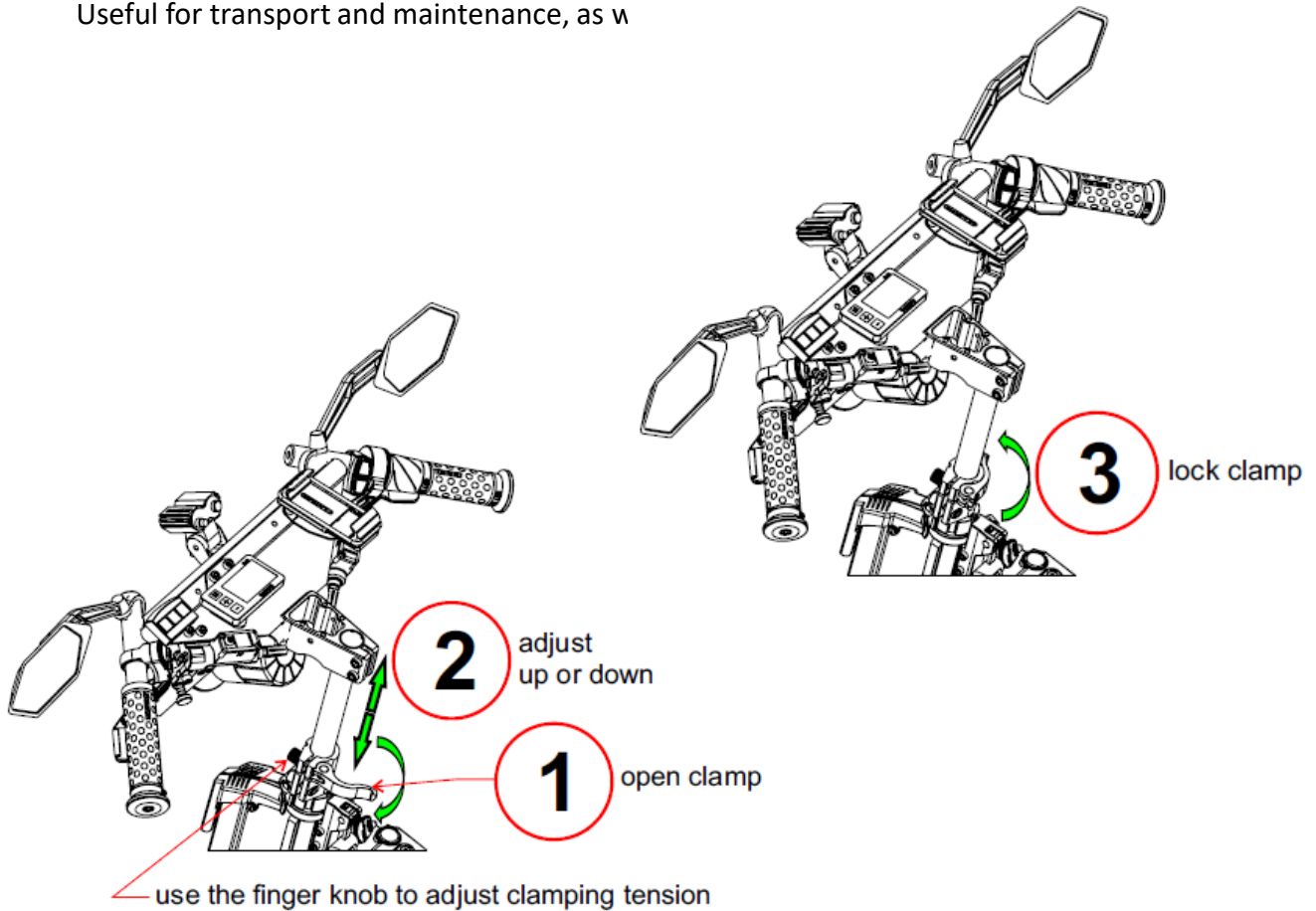

## Folding Mechanism – adjusting lock tension

Keep a good tension to eliminate any play.  
Reduce the tension for easy operation.

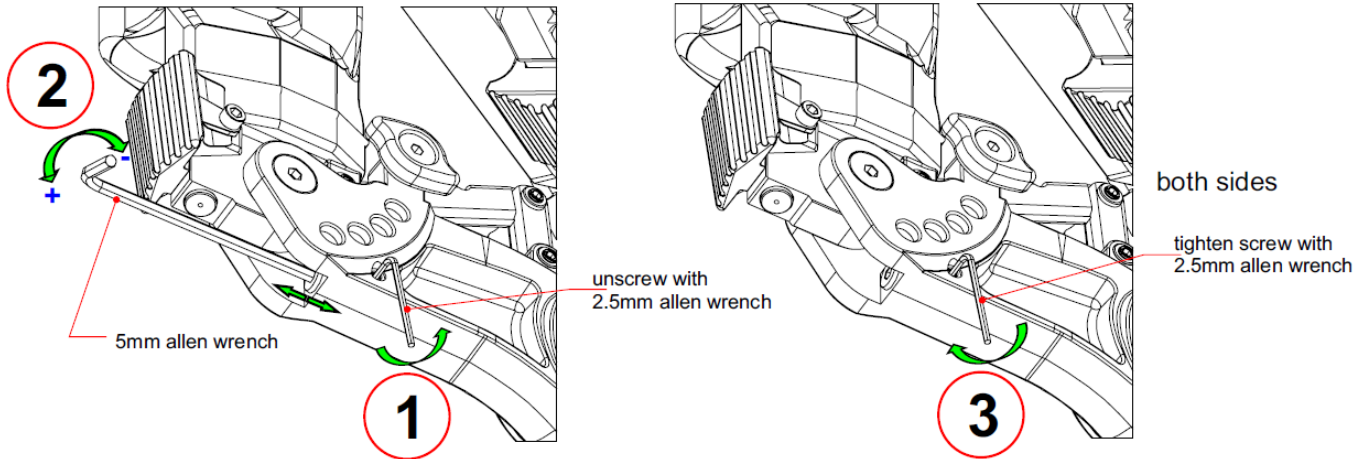

## Headlight adjustment

Adjust the headlight projection angle by tilting the headlight on the bracket.

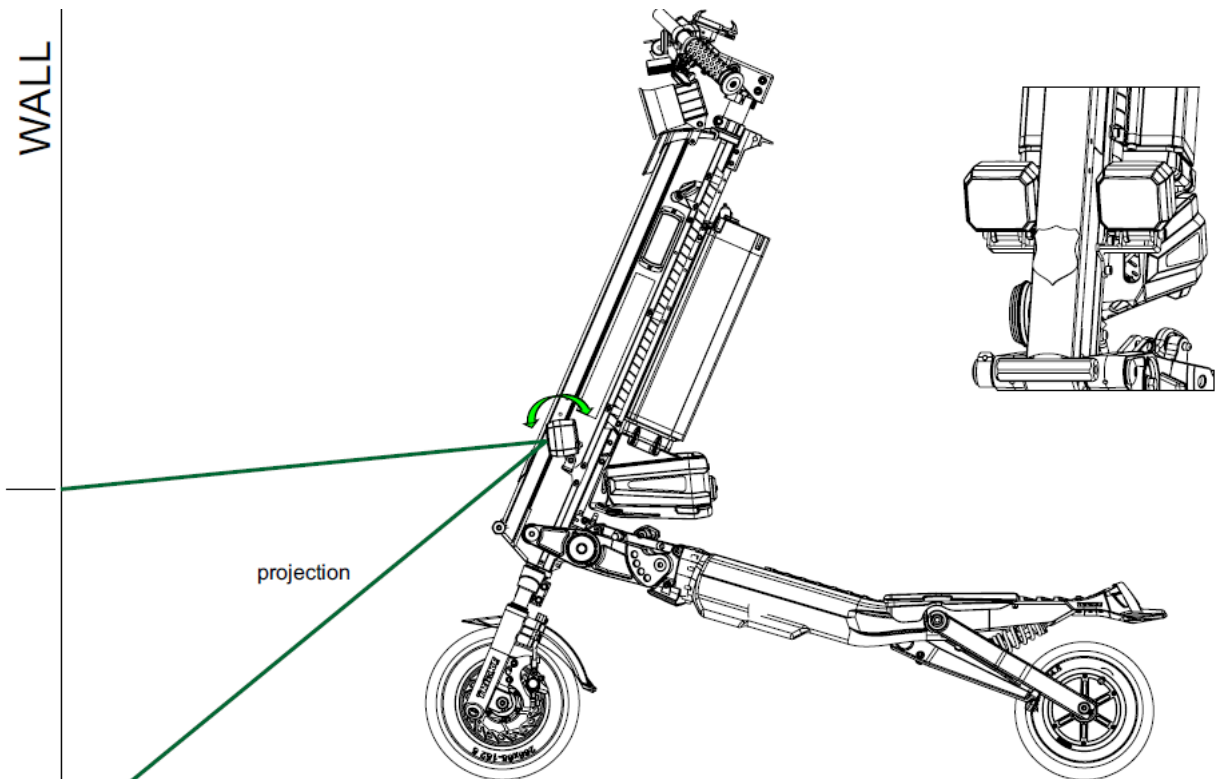

adjusting brake lever reach and parking brake tension

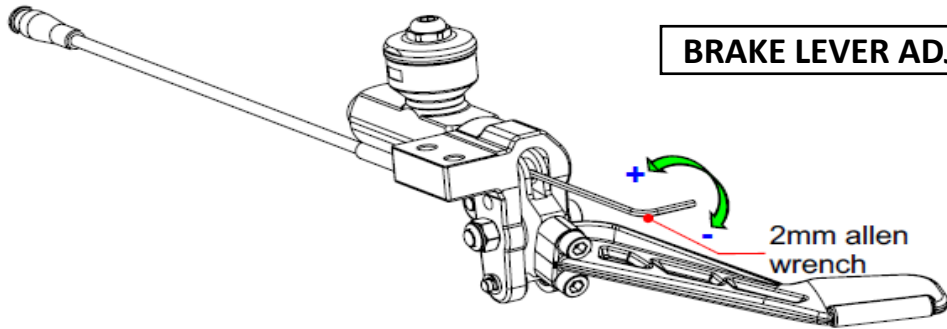

**BRAKE LEVER ADJUSTMENT**

adjusting brake switch activation  
(motor kill switch, brake light and regen brake)

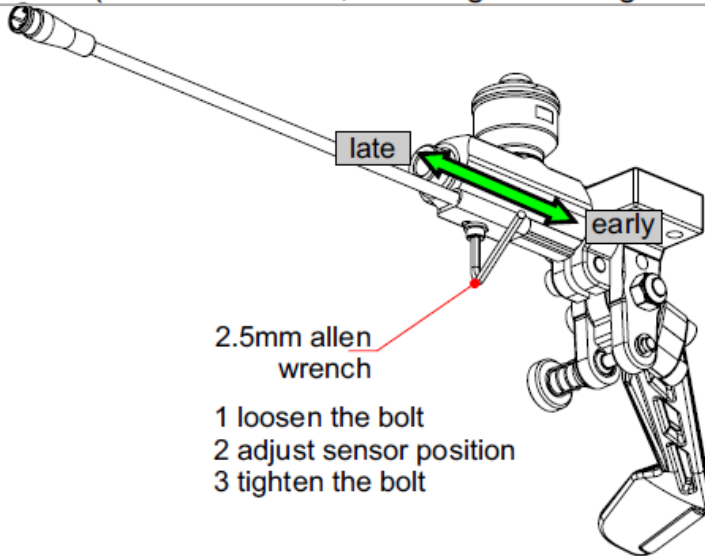

**BRAKE SWITCH  
ADJUSTMENT**

RIGHT lever = drive kill  
switch  
LEFT lever = brake light  
switch

4mm allen  
wrench

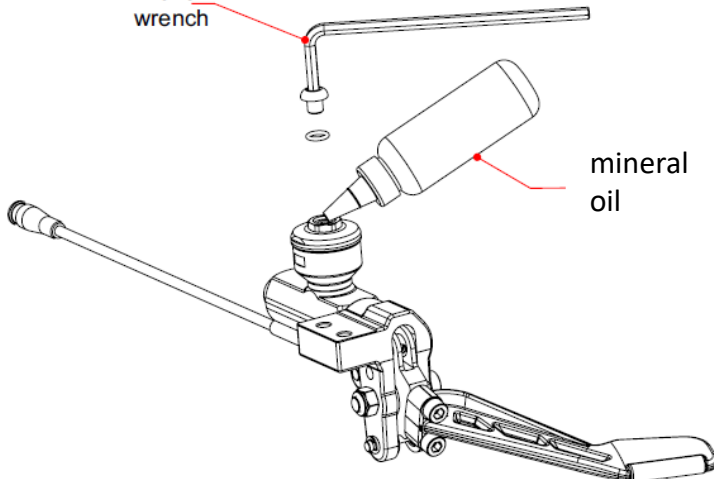

**ADDING OIL  
TO BRAKE RESERVOIR**

mineral  
oil

**MAINTENANCE**

**TIRE PRESSURE**

Check and inflate every 3 weeks!

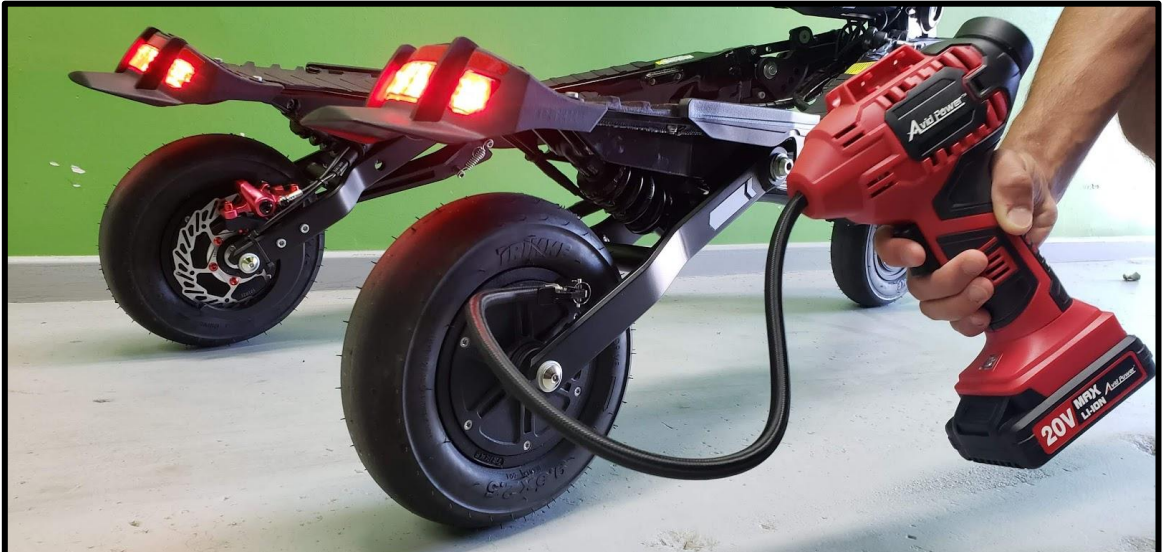

**Standard tire width 65mm**  
FR 40-50 psi RR 50-65 psi

**XL tire width 85mm**  
FR 25-30 psi RR 30-40 psi

**CLEANING:** wipe with a soft cloth and all-purpose cleaner



# BATTERY CHARGING

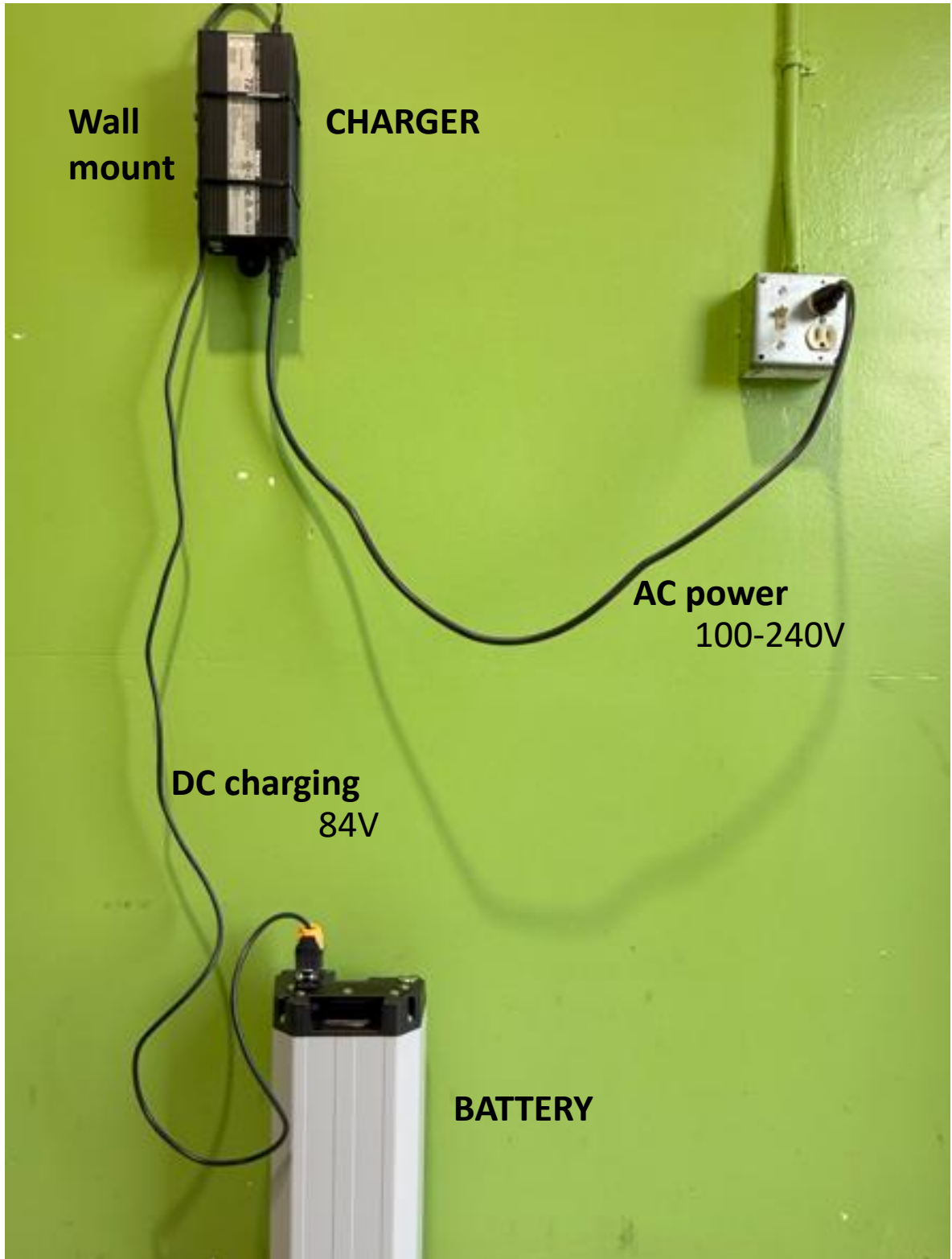

## CONNECTING

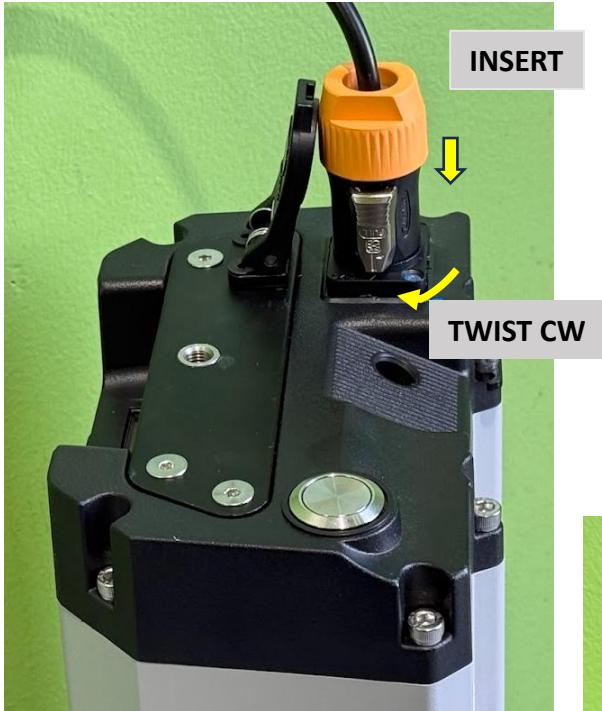

## DISCONNECTING



## CHARGER STATUS

Fan ON	
BLUE – charging in progress	
GREEN – fully charged	
Blinking GREEN – stand-by	

## CHARGING YOUR TRIKKE POSITRON BATTERY

Proper charging is crucial for the performance and longevity of your TRIKKE Positron battery. Please follow these instructions carefully.

### Important Safety Precautions Before Charging:

- **Use ONLY the Original Charger:** Always use the charger specifically designed and provided by TRIKKE Tech for your Positron battery. Using an incompatible charger can damage the battery, cause a fire, or create a shock hazard.
- **Inspect Equipment:** Before each charge, inspect the charger, cables, and battery charging port for any signs of damage (cracks, fraying, bent pins). If you notice any damage, do NOT attempt to charge. Contact TRIKKE Tech Support immediately.
- **Safe Charging Environment:**
  - Charge in a dry, well-ventilated area, away from flammable materials, direct sunlight, and extreme temperatures.
  - Ensure the charger is placed on a stable, flat surface (like a table or mounted to a wall) to prevent it from falling.
  - Do NOT obstruct the charger's cooling fan. Maintain at least 2 inches (5cm) of clear space around the fan for proper airflow.
  - Protect the charger from moisture. Never charge if the charger or battery has been exposed to rain, water, or flooding. If contact with water occurs, discontinue use and contact TRIKKE Tech Support.
- **Adult Supervision:** Charging should be performed by an adult or under adult supervision.
- **No Unattended Charging:** For optimal safety, it is strongly recommended to monitor the charging process. Avoid leaving the battery to charge overnight or unattended for extended periods.

### **Step-by-Step Charging Procedure:**

#### **1. Prepare the Battery:**

The battery can be charged either while installed in the vehicle or when removed.

Ensure the battery and its charging port are clean and dry.

#### **2. Connect the Charger to AC Power:**

Plug the charger into a standard AC wall outlet.

#### **3. Connect the Charger to the Battery:**

Align the charger connector with the battery's charging port according to the imprinted markings.

Insert the connector fully and then twist it clockwise until you hear and feel a distinct "click." This ensures a secure connection.

#### **4. Monitor the Charging Process:**

##### **Charger Indicator Lights:**

The charger's cooling fan will start (you will hear it), and an indicator light (typically blue or red) will illuminate, signaling that charging is in progress. If the battery is already fully charged, the charger may not initiate a new charging cycle, and the light may indicate a "stand-by" or "fully charged" state (typically green).

**Charging Complete:** Once the battery reaches a full charge, the charger will automatically stop the charging process and switch to a stand-by mode. The indicator light will typically change to green.

#### **5. Disconnect the Charger:**

Once charging is complete, it is recommended to disconnect the charger.

First, disconnect the charger from the battery by twisting the connector counter-clockwise and gently pulling it out.

Then, unplug the charger from the AC power outlet.

### **Important Notes on Charging:**

**Do Not Force Connections:** If the connector does not insert easily or click into place, double-check the alignment. Do not force it, as this could damage the port or connector.

**Charger Safety:** Never attempt to open the charger casing. It contains high voltage and poses a significant shock hazard.

## **BATTERY CARE & SAFETY INSTRUCTIONS**

Your TRIKKE Positron battery is a high-performance component. Proper care and handling are essential for safety, longevity, and optimal performance.

### **General Battery Safety:**

**Use Original Equipment:** Only use the original TRIKKE Positron charger supplied with your battery.

### **Avoid Physical Damage:**

Never attempt to open, disassemble, or tamper with the battery enclosure. The battery contains high voltage and hazardous materials, posing a risk of electric shock, explosion, personal injury, or fire.

If the battery case appears crushed, cracked, punctured, or otherwise damaged, it is unsafe. Cease operation immediately and contact TRIKKE Tech Support.

**Report Abnormalities:** If you observe any unusual battery behavior (e.g., strange odors, overheating, swelling, leaking, erratic performance), discontinue use immediately and contact TRIKKE Tech Support for guidance.

### **Storage:**

**Cool and Dry:** Store the battery in a cool, dry, and well-ventilated place, away from direct sunlight, heat sources, and flammable materials.

**Temperature:** Avoid exposing the battery to extreme temperatures during storage.

**Long-Term Storage:** If you plan to store the battery for an extended period (e.g., more than a month), it is recommended to maintain a charge level of approximately 40-60%. Check and recharge to this level periodically (e.g., every 2-3 months) if needed. Do not store a fully depleted or fully charged battery for long periods.

### **Operating Conditions:**

#### **Temperature Range:**

**Operation:** The TRIKKE Positron can be operated in ambient temperatures ranging from -10°C (14°F) to 40°C (104°F).

**Charging at Low Temperatures:** For charging in ambient temperatures below 0°C (32°F), it is highly recommended to bring the battery indoors and allow it to warm up to a temperature above 5°C (40°F) before initiating charging. This will help ensure a full charge and protect battery health. Charging at very low temperatures can reduce charging capacity and potentially damage the battery.

### **Hot Weather Operation:**

The battery will naturally generate some heat during use (discharge).

In high ambient temperatures, especially when using high power settings for extended periods, the battery's internal temperature may rise.

Your battery is equipped with a thermal protection system. If the internal temperature becomes too high, the battery may automatically shut down to prevent damage. It will remain off until it cools to a safe operating temperature.

### **Recommendations for Hot Weather:**

Whenever possible, select a lower power setting.

Avoid prolonged use of high-power settings.

Avoid parking the vehicle or leaving the battery in direct sunlight for extended periods.

### **Moisture:**

The vehicle and battery can be operated during light rain.

However, avoid leaving the vehicle with the battery installed parked in heavy rain or in conditions where it could be submerged.

If the battery becomes significantly wet or submerged, do not use or charge it.

Contact TRIKKE Tech Support.

### **Transportation & Disposal:**

**Transportation Restrictions:** Lithium-ion batteries of this size are subject to transportation regulations. They are typically restricted from transport in the cargo hold or cabin of passenger aircraft. Adhere to all applicable local, national, and international shipping regulations when transporting the battery.

**Proper Disposal:** Do NOT dispose of the battery in household trash. Lithium-ion batteries require special disposal procedures to protect the environment and prevent safety hazards. Locate an authorized battery collection and recycling center in your area. You can often find resources by visiting websites like [Call2Recycle.org](http://Call2Recycle.org) (or an equivalent service in your region). Follow all local regulations for battery disposal.

### Removing/installing FRONT wheel

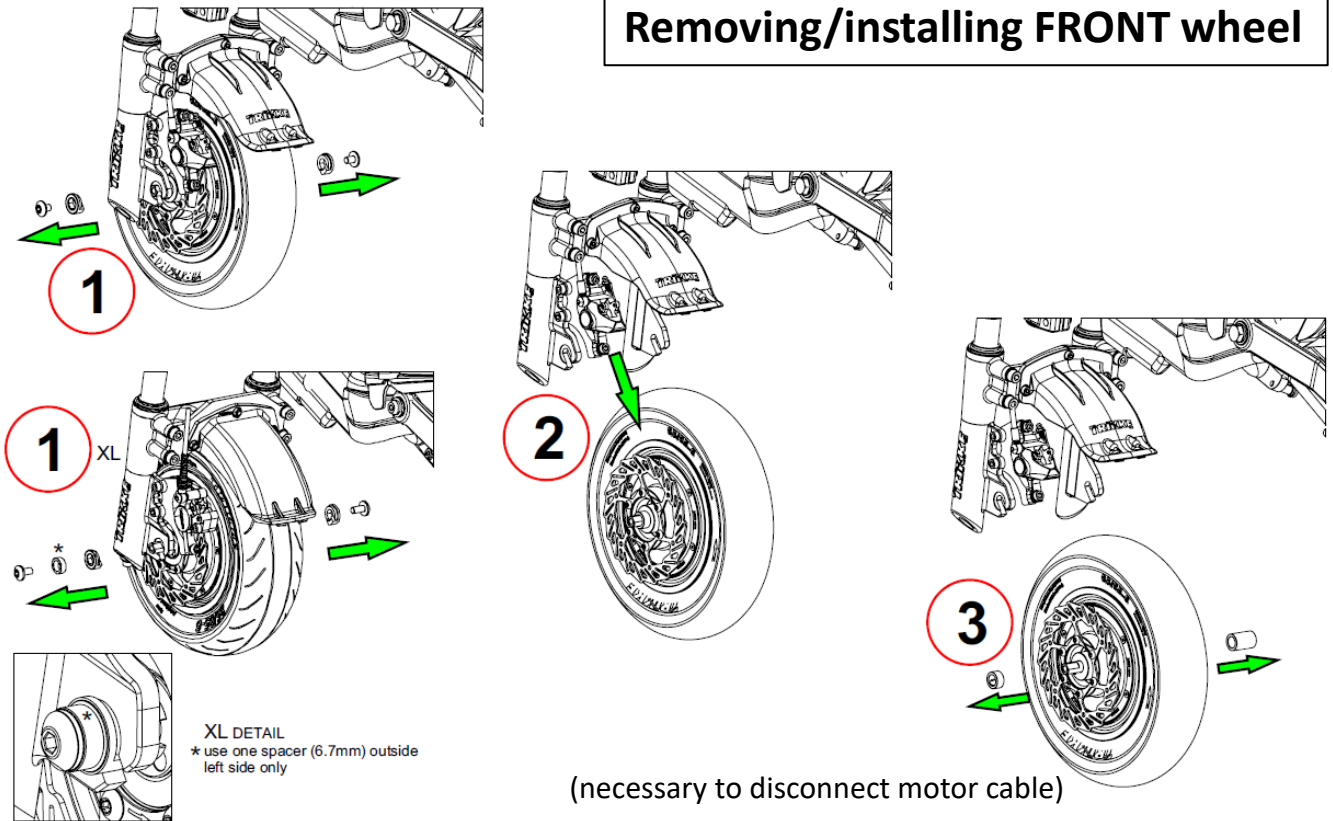

### Removing/installing REAR wheel

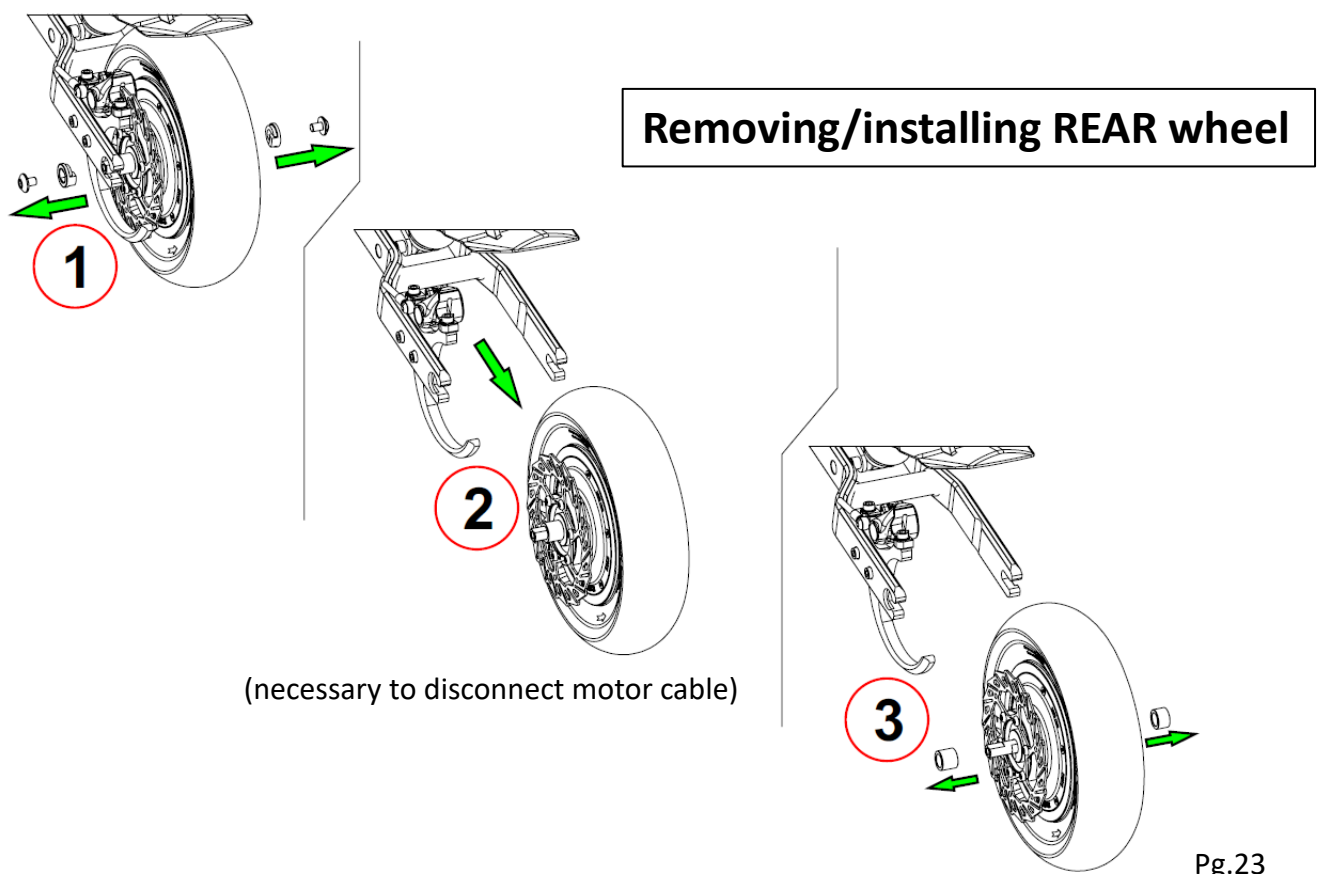

## Replacement Tire and Tube

front and rear

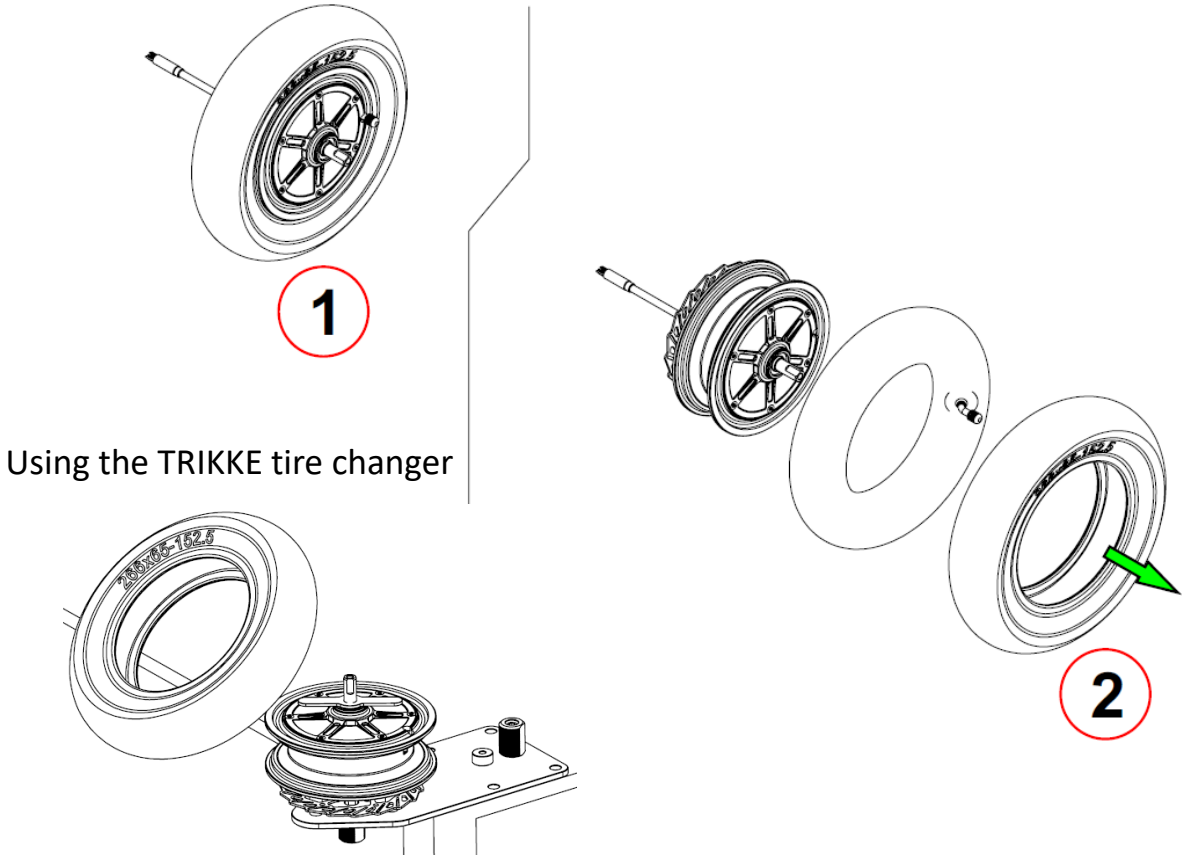

## Replacement Solid Tire Option

front and rear

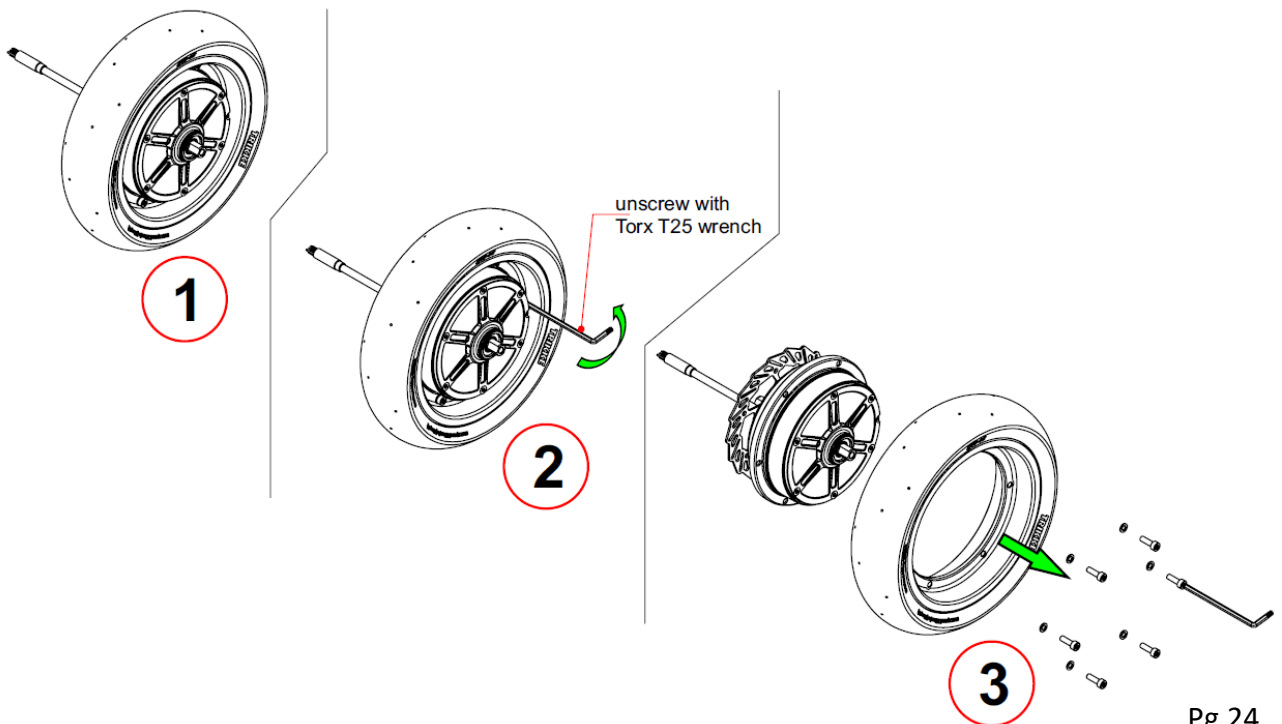

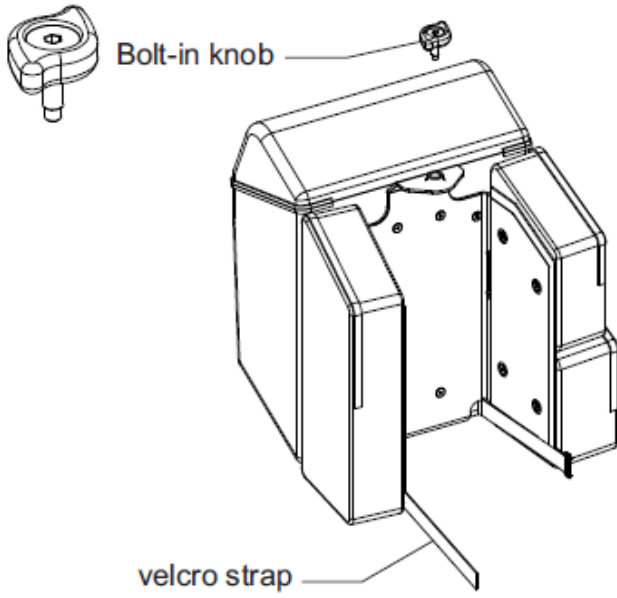

**Mounting the GEAR BAG  
to the battery**

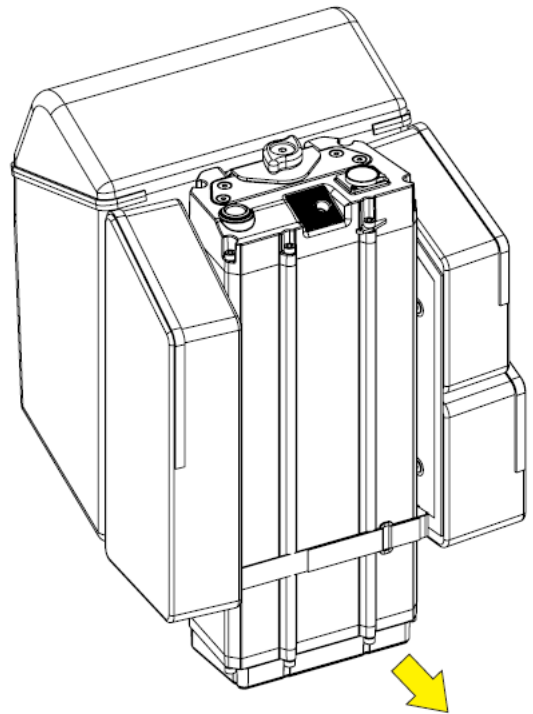
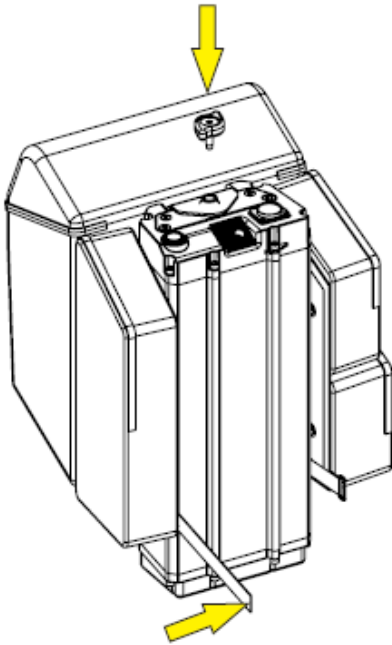
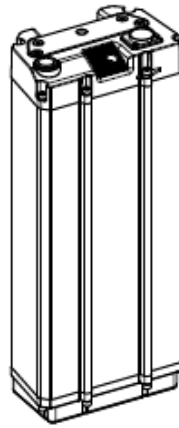

mount to the Trikke

## Rear View MIRRORS Installation and Alignment

Position and tighten the clamp to secure the mirror assembly to the handlebar... (4mm allen wrench).  
Notice the angle shown in the image.  
Make sure both sides are evenly positioned.

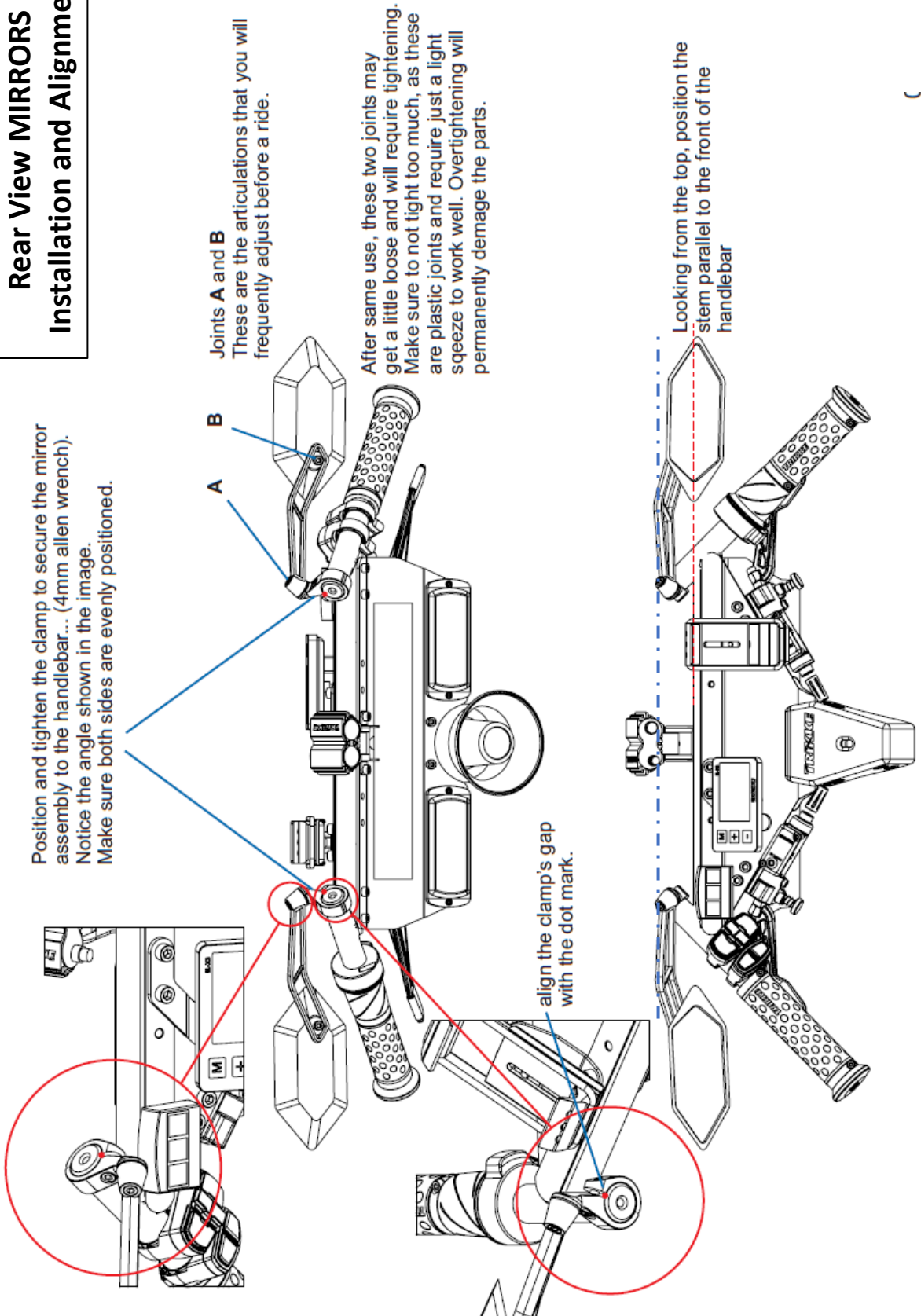

**Joints A and B**  
These are the articulations that you will frequently adjust before a ride.

After same use, these two joints may get a little loose and will require tightening. Make sure to not tight too much, as these are plastic joints and require just a light squeeze to work well. Overtightening will permanently damage the parts.

## General Dimensions

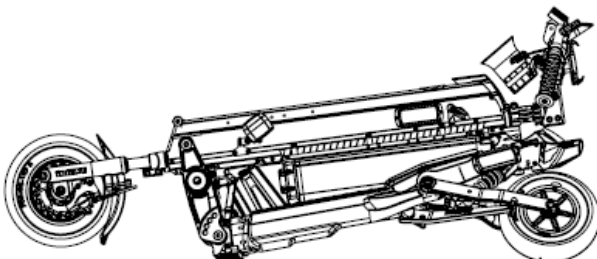
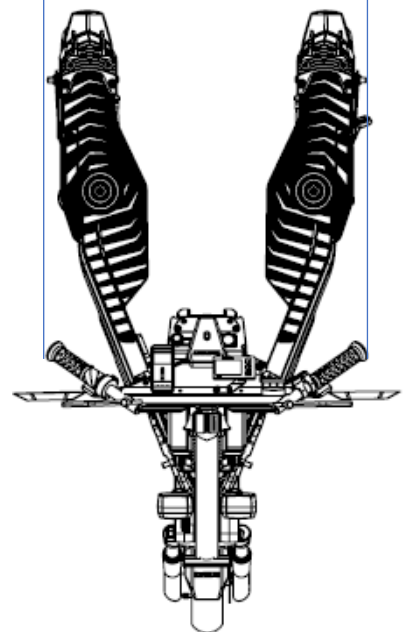
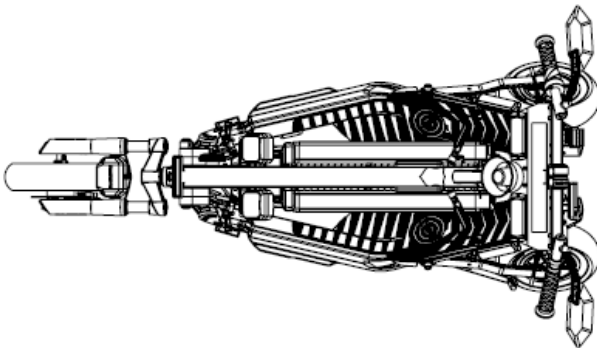
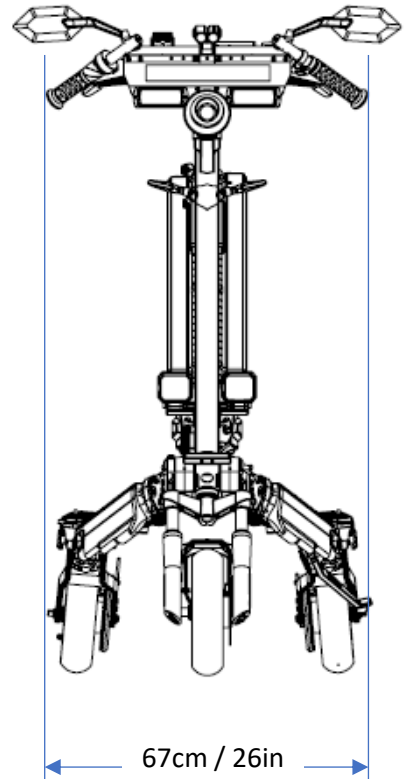
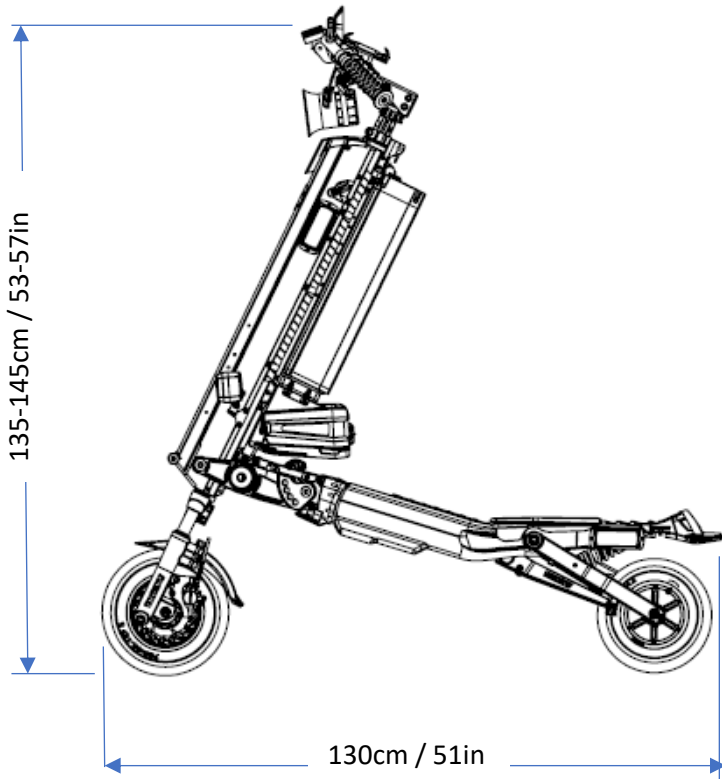

## Specifications and Features

	POSITRON 60V AWD	POSITRON 72V ELITE	POSITRON 72V XL
electric drive system	DC 60V - 40A	DC 72V - 52A	DC 72V - 65A
acc line	DC 12V	DC 12V	DC 12V
battery (Li-ion)	60V 1470Wh	72V 1764Wh	72V 1764Wh
charging V / A / time	67.2V 5A 4h	84V 5A 4h	84V 10A 2h
electric rated power	1150W	1872W	2340W
electric peak power	2300W	3744W	4680W
traction power (brake power)	<b>1738W</b>	<b>2800W</b>	<b>3500W</b>
traction	3WD	3WD	3WD
motor	3x BLDC direct drive	3x BLDC direct drive	3x BLDC direct drive
motor controller	3x FOC 2x15A 1x10A	FOC 2x20A 1x12A	FOC 2x25A 1x15A
max rider's weight	300lbs (135kg)	300lbs (135kg)	<b>350lbs (152kg)</b>
Vehicle weight (w/battery)	90lbs (41kg)	100bs (45kg)	105bs (45kg)
frame	AL6061 - foldable	AL6061 - foldable	AL6061 - foldable
overall dimensions	L51" x H57" x W26"	L51" x H57" x W26"	<b>L53" x H58" x W27"</b>
adjustable handlebar height	5" (12.5cm)	5" (12.5cm)	5" (12.5cm)
deck height	11" (28cm)	11" (28cm)	11" (28cm)
tires	inflatable 60psi (4.1Bar)	inflatable 60psi (4.1Bar)	inflatable 35psi (2.5Bar)
phone holder	standard	standard	standard
gear bag	standard	standard	standard
emergency lights	standard - 5	standard - 7	standard - 7
LED headlight	2x 2000 lm with DRL	2x 2000 lm with DRL	2x 2000 lm with DRL
rear lights	dual running/brake/turn	dual running/brake/turn	dual running/brake/turn
beep horn	yes	yes	yes
siren	3-tone police siren	3-tone police siren	3-tone police siren
RFID key	standard	standard	standard
rear suspension	swing arm spring/oil adjust	swing arm spring/oil adjust	swing arm spring/oil adjust
front suspension	telescopic spring/oil damper	telescopic spring/oil damper	telescopic spring/oil damper
hydraulic disc brakes	all wheel - 2 levers	all wheel - 2 levers	all wheel - 2 levers
climbing ability (200lbs)	15% (9deg)	22% (12deg)	27% (15deg)
* top speed (unregulated)	35mph (56km/h)	44mph (70km/h)	44mph (70km/h)
** range mixed terrain (200lbs)	up to 22 miles (35km)	up to 25 miles (40km)	up to 25 miles (40km)
** range on flat terrain (200lbs)	up to 30 miles (48km)	up to 35 miles (56km)	up to 35 miles (56km)

(\*) max speed can be locked at any level by factory

(\*\*) range will vary depending on topography, tire pressure, average speed, start/stop pattern, power level setting

Scan to watch online video  
Basic Riding Orientation



## SAFE RIDING:



- It is recommended the rider receive basic riding and safety training before operating the vehicle. Official training available by Trikke Tech, California.
  - Rider must learn and understand the safety aspects of riding and operation.
  - Rider must get familiar with all features of the vehicle.
  - It is highly recommended to wear a safety helmet.
- 
- *Stand on the vehicle in a straight up posture.*
  - *Grip handlebars with both hands at all time.*
  - *Do not lean back or pull up on the handlebars*
  - *Do not lean over the handlebar.*
  - *Do not turn sharply. Make smooth and progressive turns.*
  - *Be aware of the terrain around you. Scan for debris and obstacles as you ride.*
  - *Watch for traffic of cars and pedestrians.*
  - *Reduce speed to a walking pace around pedestrians, be courteous.*
  - *Although it is a stable platform, there are always conditions that vary with the environment, which may surprise you, such as cracks in the pavement, sand, gravel, potholes, tree branches, people or other vehicles. Falls and accidents can occur.*

## SAFETY EQUIPMENT:



ALWAYS USE SAFETY EQUIPMENT, ESPECIALLY A HELMET. A helmet is essential when riding a Trikke EV or any exposed wheeled vehicle.

We also recommend that you wear gloves, elbow and knee pads for additional protection.



## Product Life Cycle

The Trikke™ Trikke EV vehicle has a lifecycle. The duration of this cycle varies with the maintenance and care received during their time of use, and the type and amount of use that the vehicle is subjected. The vehicle must be inspected periodically by observing indicators of fatigue and other indicators of potential problems. These are very important safety checks to help prevent accidents, injuries to the rider and shortening the lifecycle of the vehicle.

THIS IS AN INTEGRATED AND FINAL STATEMENT OF TRIKKE'S LIMITED WARRANTY. COMPANY DOES NOT AUTHORIZE OR ALLOW FOR ANYONE, INCLUDING ITS AUTHORIZED DEALERS OR REPRESENTATIVES, TO EXTEND ANY OTHER WARRANTIES, EXPRESS OR IMPLIED. NO OTHER REPRESENTATION AND NO STATEMENT OF ANYONE BUT THE COMPANY, INCLUDING A DEMONSTRATION OF ANY KIND BY ANYONE, SHALL CREATE ANY WARRANTY REGARDING THE TRIKKE CAMBERING VEHICLE. ALL OF THE REMEDIES AVAILABLE TO THE ORIGINAL OWNER ARE STATED HEREIN.

IT IS AGREED THAT TRIKKE TECH, INC.'S LIABILITY UNDER THIS LIMITED WARRANTY SHALL BE NO GREATER THAN THE AMOUNT OF THE ORIGINAL PURCHASE PRICE AND IN NO EVENT TRIKKE TECH, INC. BE LIABLE SHALL FOR INCIDENTAL OR CONSEQUENTIAL DAMAGES.

## DISCLAIMER

All other remedies, obligations, liabilities, rights, warranties, express or implied, arising from law or otherwise, including but not limited to, any claimed implied warranty of merchantability, any claimed implied warranty arising from course of performance, course of dealing or usage of trade, and any claimed implied warranty of fitness, are disclaimed by Company and waived by the original owner.

Some states, jurisdictions, countries, do not allow some or all of the limitations set for herein, or the exclusion or limitation of incidental or consequential damages. If any provision is found unenforceable, only that provision shall be stricken, and all others shall apply. This limited warranty does provide the original owner with certain legal rights and recourse and the original owner may possess other rights or recourse, depending on the state, jurisdiction

## TRIKKE POSITRON STANDARD COMMERCIAL WARRANTY



Trikke Tech warrants this product (including all components) against defects in material or workmanship as follows:

### **Frame - 3 years Limited Warranty**

Trikke Tech electric vehicle frames include a 3-year warranty covering geometry defect structural failure. Trikke Tech reserves the right to replace individual parts or the whole frame. Individual parts may not match the original frame color. Failure to originate by misuse, accidents or abuse are excluded.

Other components are warranted for **12 months**. In the event of a defective or faulty part, Trikke Tech will ship the replacement part free of charge and Customer will be responsible for performing the replacement. Exclusions: parts subject to normal wear and tear. Brake lines, brake pads, tires, inner tubes, bearings and trim components will be replaced for claims within the first 30 days of purchase. These parts are not covered by any additional warranty.

### **Lithium-ion Battery - 12 months Limited Warranty**

Lithium-ion batteries originally installed on a Trikke electric vehicle or a replacement battery purchased from Trikke Tech, its distributors or authorized dealers are warranted for 12 months from the original purchase, with full replacement within the first 45 days, and partial (pro rate) replacement after the initial 45 days of use. A suspect battery must be shipped to Trikke Tech for warranty, the Customer being responsible for shipping and costs.

Trikke Tech will then check the battery and either repair or replace it. The battery will be returned to Customer at Trikke's expense. Pro-rata replacement takes into consideration the full number of months passed since the purchase date and divides the base retail price of a new battery by 12 (twelve). If a new battery is required, Customer will be expected to pay 1/12 of the retail cost of the battery for every month of use (if after 45 days of use).

Purchases of replacement battery under pro-rata warranty must be directly from Trikke Tech. The new battery will be warranted with a new term of 12 month under the same conditions described above. Important facts about the aging of lithium-ion batteries: The current technology of lithium-ion batteries presents a natural degradation (aging, loss of capacity) even if not in use. The level of degradation will depend on factors like discharge current (fast or low riding speed setting), temperature of operation/storage and the number of cycles of discharge. Trikke Panasonic/Samsung/LG batteries cells should retain a minimum of 70% of the original capacity at **500 recharges** if operated at normal power level and at temperatures ranging between 32-100F (0-40C).

Exclusions: Damages to the battery caused by short circuit, moisture, impact, perforation, abuse or marks of tampering with the battery pack will void the above warranty. Batteries kept discharged for long periods of time may not recover working capacity and will be permanently damaged – failure to keep the proper charge level of battery will void the warranty.

**TRIKKE POSITRON  
STANDARD COMMERCIAL WARRANTY**



**Electrical Components - 12 months Limited Warranty**

Electrical components, including motor, electronic controller, throttle and associated parts (excluding the battery) carry a 12 months warranty from the original purchase date. Failure originated by water, misuse, accidents or abuse are excluded. Warranty is limited to the replacement of the part. Defective parts must be shipped to Trikke Tech or presented to an authorized service center for analysis prior to replacement.

LIMITATIONS ON WARRANTY THE ABOVE WARRANTY IS THE ONLY REMEDY PROVIDED BY TRIKKE TECH FOR ITS ELECTRIC VEHICLES. NO OTHER PARTY HAS EXPRESS OR IMPLIED AUTHORITY TO CHANGE THIS WARRANTY IN ANY MANNER. TRIKKE TECH DISCLAIMS ANY LIABILITY FOR SPECIAL, INCIDENTAL OR CONSEQUENTIAL DAMAGES.

**COMMERCIAL WARRANTY APPLIES “FOR COMMERCIAL USE”**

\*\*\* Available **EXTENDED Commercial Warranty** (please consult sales department)

Frame – Total 5 years

Lithium-ion Battery – Total 24 months

Electrical Components – Total 24 months

## TRIKKE 3CV TECHNOLOGY

The unique 3CV technology developed by Trikke Tech uses a mechanism that allows the Trikke EV frame to camber and the wheels to adapt to the terrain, and the vehicle to lean into turns while keeping the three points of support always in contact with the ground to ensure optimal stability at any speed. This cambering mechanism is elegantly simple and provides the necessary rigidity, geometry and assistance to the rider's motion, to allow a greater control, speed, comfort, durability and above all the full confidence of riding

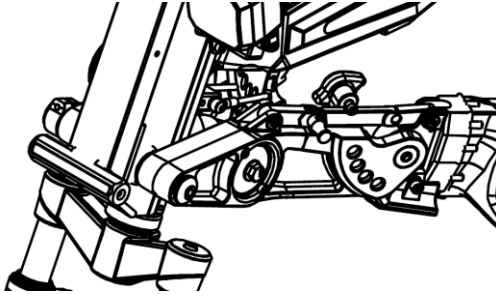

## Patent and Trademark Information

The TRIKKE EV vehicle is a product developed by TRIKKE TECH, INC. Protected by US and International patents.

**TRIKKE, TRIKKE EV and POSITRON** are trademarks of Trikke Tech, Inc.



## Contact Information

Website: [www.trikkemobility.com](http://www.trikkemobility.com)

E-mail: [info@trikke.com](mailto:info@trikke.com)

Phone: 1-805-693-0800

**Trikke Tech, Inc.**

132 Easy Street – suite D1

Buellton, CA – USA zip code 92427



**This manual and its contents are property of Trikke Tech. Inc.  
No portion of the text or images in this manual can be reproduced  
without prior written permission of Trikke Tech, Inc.**

**Copyright © 2024 Trikke Tech, Inc.**

**All Rights Reserved 2024**

**TRIKKE™** PROFESSIONAL  
MOBILITY



# Owner's Manual

Models:

POSITRON 60V

POSITRON 72V

Rev. Jun 2025